

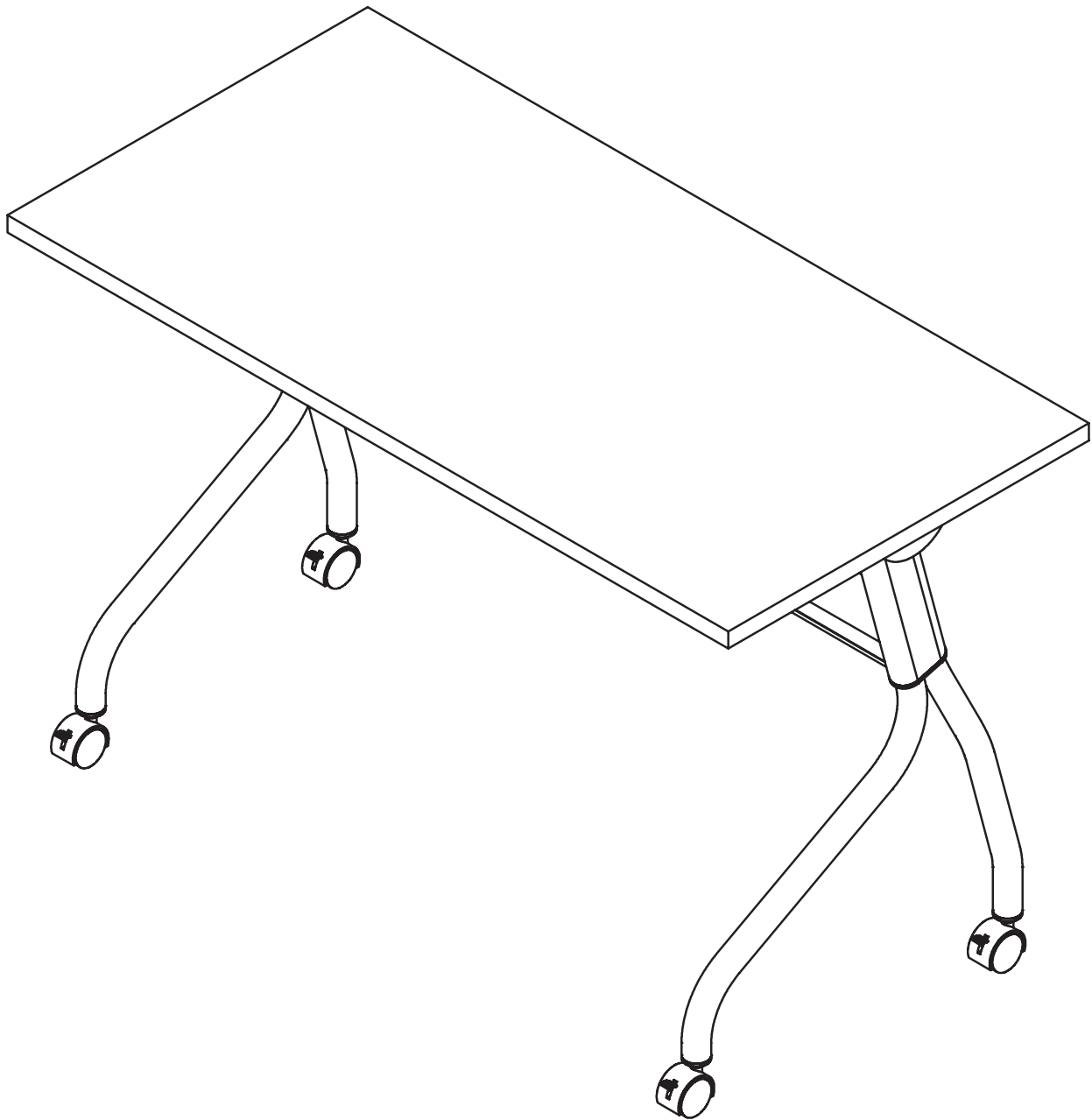

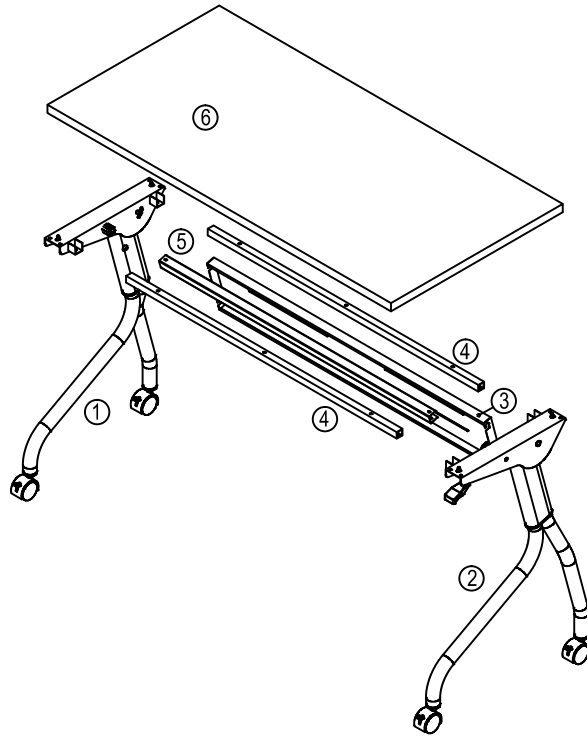

ML4824FT / ML6024FT / ML7224FT



EXPLODED VIEW



HARDWARE LIST

			
Ax 8+2 (M6x8)	Bx 4+2 (M6x16)	C X1 (4mm)	D X1 (5mm)

STEP 1 - Attach Modesty Panel

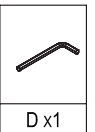
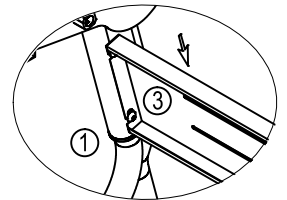
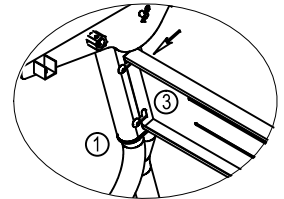
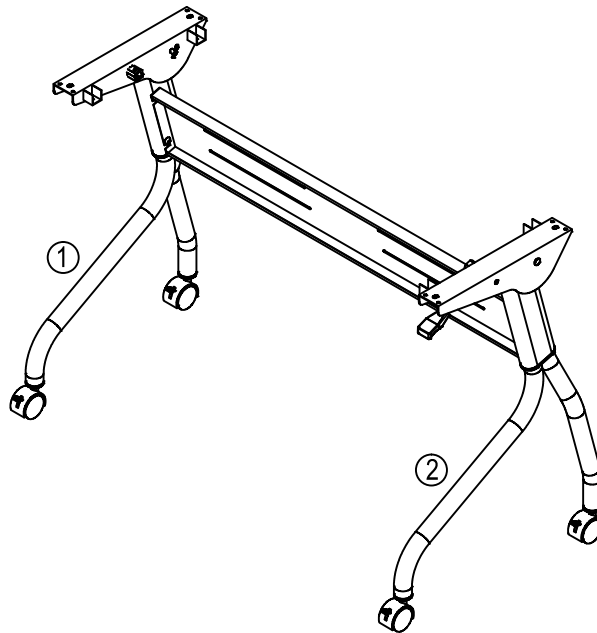

- **Attach modesty panel (Item 3).**
- **Once modesty panel is in place, tighten all screws.**

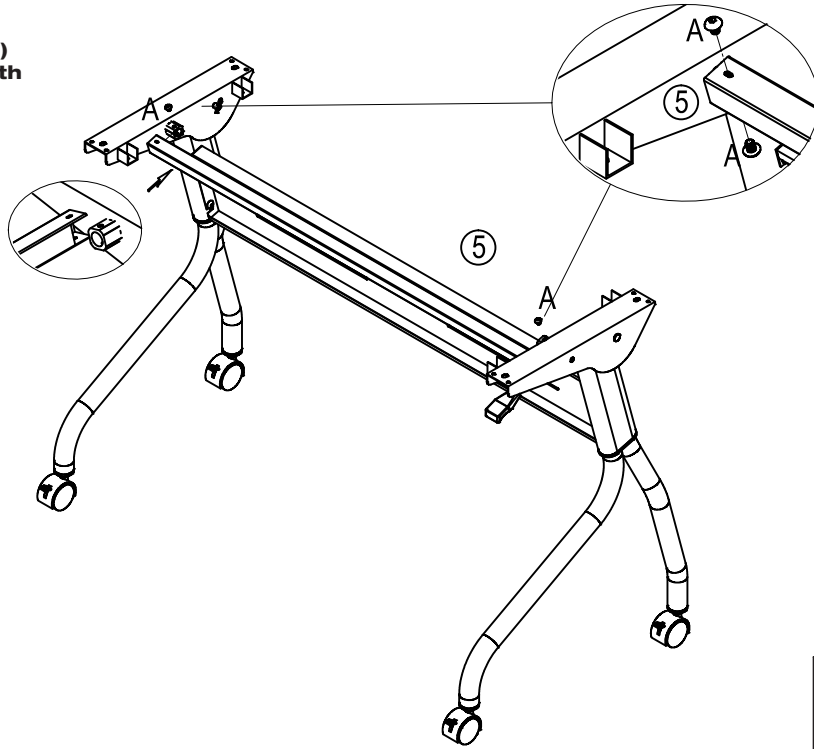

STEP 2 - Attach Center Support Beam

- Insert center support beam (Item 5) into center slots on leg and affix with screws (Item A).
- Do not tighten these screws until after Step 3.





	
A x4	C x1

STEP 3 - Attach Outer Support Beams

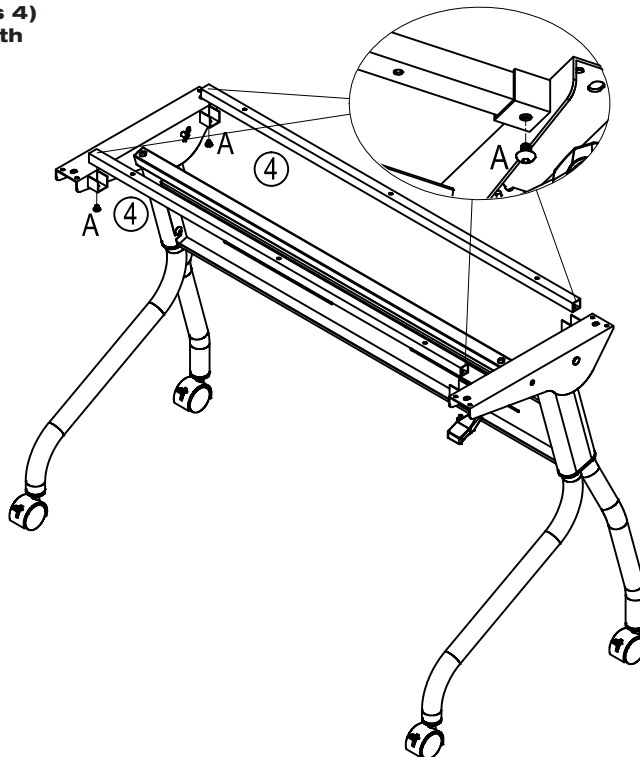
- Insert outer support beams (Items 4) into outer slots on leg and affix with screws (Item A).
- Tighten all screws securely.



	
A x4	C x1

STEP 4 - Attach Table Base to Top

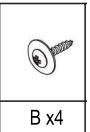
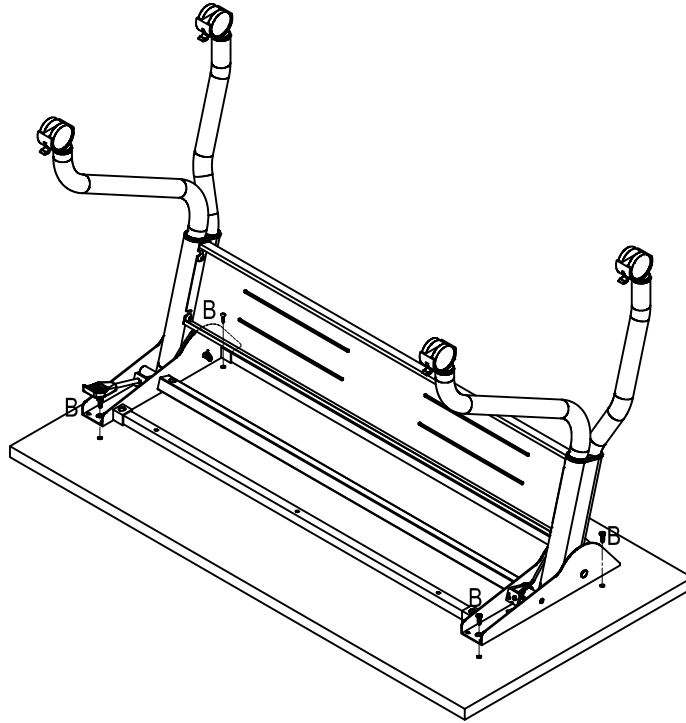

STEP 5 - Operating the Table

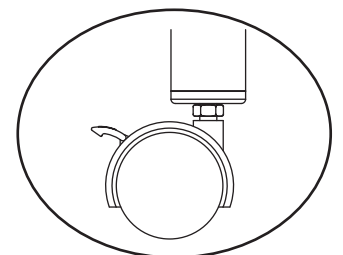
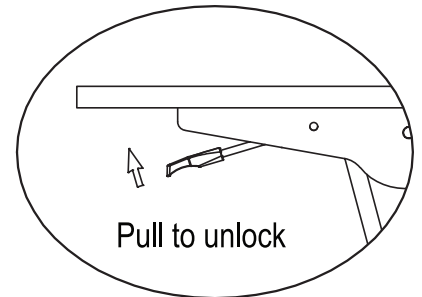
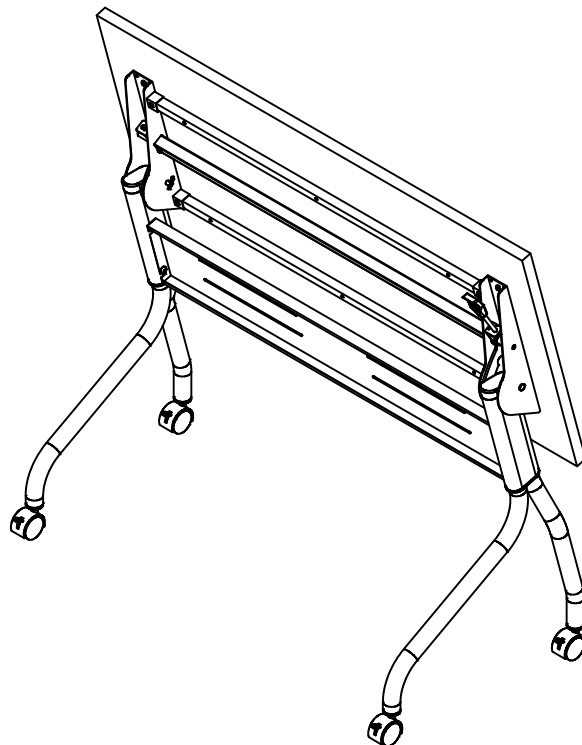

Down position locked
Up position unlock