

NL23BBF

Assembly Instructions

Thank you for purchasing this product from Global. Before you begin assembly, check that you have all the parts and hardware shown on this page.

If there is any item missing, circle the item, indicating quantity required and return to us by fax or mail:

CANADA

Global Upholstery
560 Supertest Road
Downsview, Ont.
M3J 2M6
TEL. (416)661-3660
FAX. (416)661-4300
Attn.: Customer Service

US

Global Industries Inc.
17 West Stow ROAD
P.O. 524
Marlton, NJ 08053
TEL. (856)596-3390
FAX. (856)596-5684
Attn.: Customer Service

TOOLS REQUIRED



WRENCH
size #16 or 5/8"

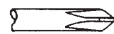

PHILLIPS
Screwdriver size #2

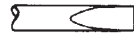

FLAT SCREWDRIVER

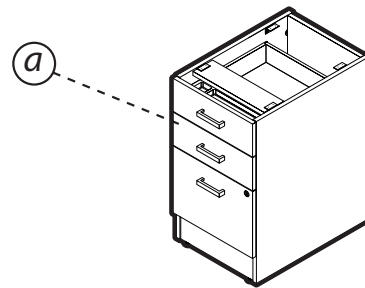

a. Storage Shell

Notice to installers:
Open and assemble only one product at a time to avoid a potential mix up of parts and hardware.

It is advisable to assemble unit on a carpet to avoid scratches.

NAIN 03 rev: 00

FST030
#8 x9/16 Pan HD.



X 8

Step **1**

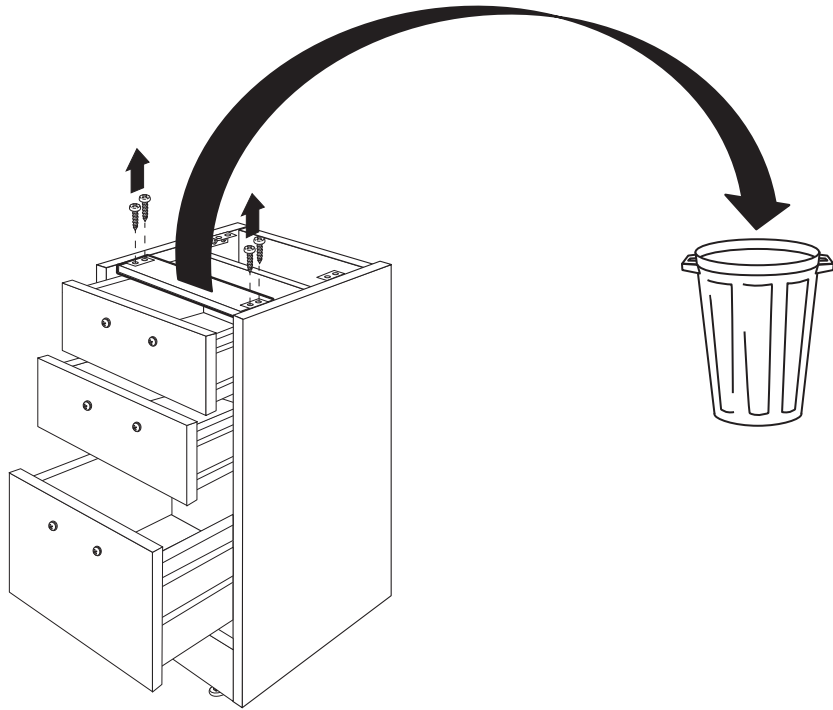

Step **2**

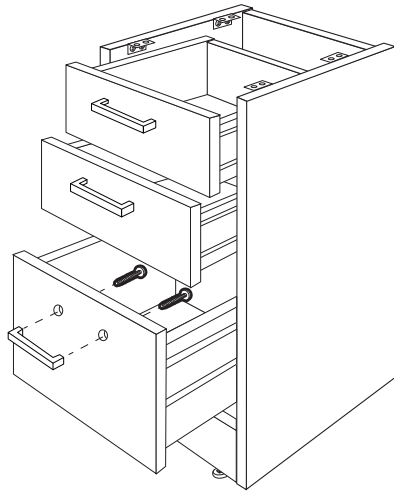

Step **3**

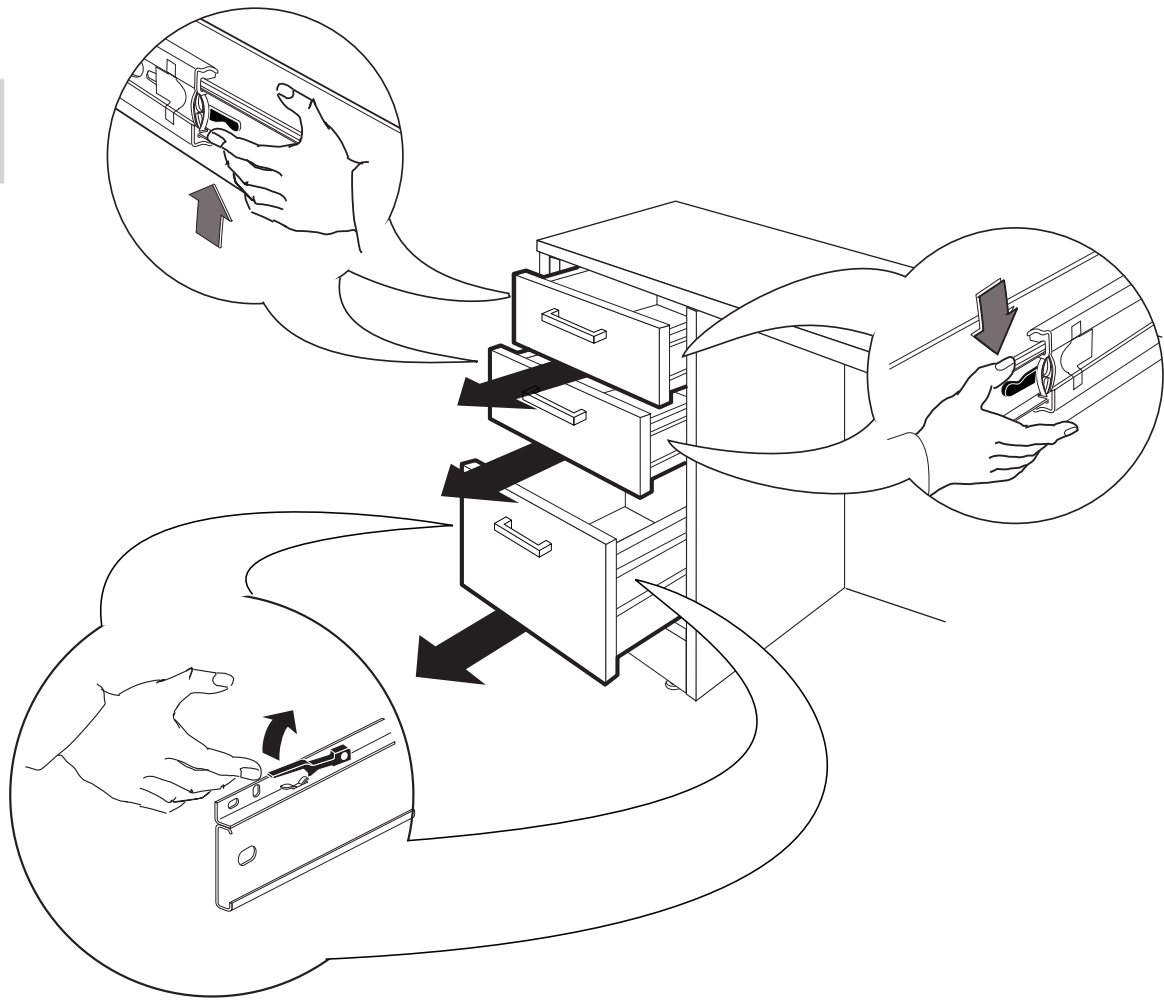

Step **4**

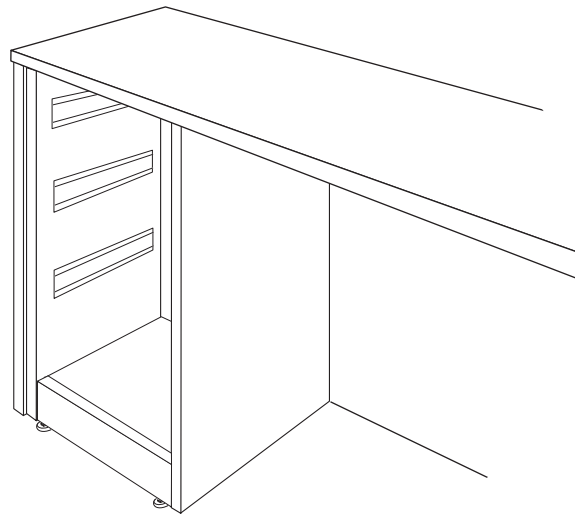

Step

5

FST030



X 8

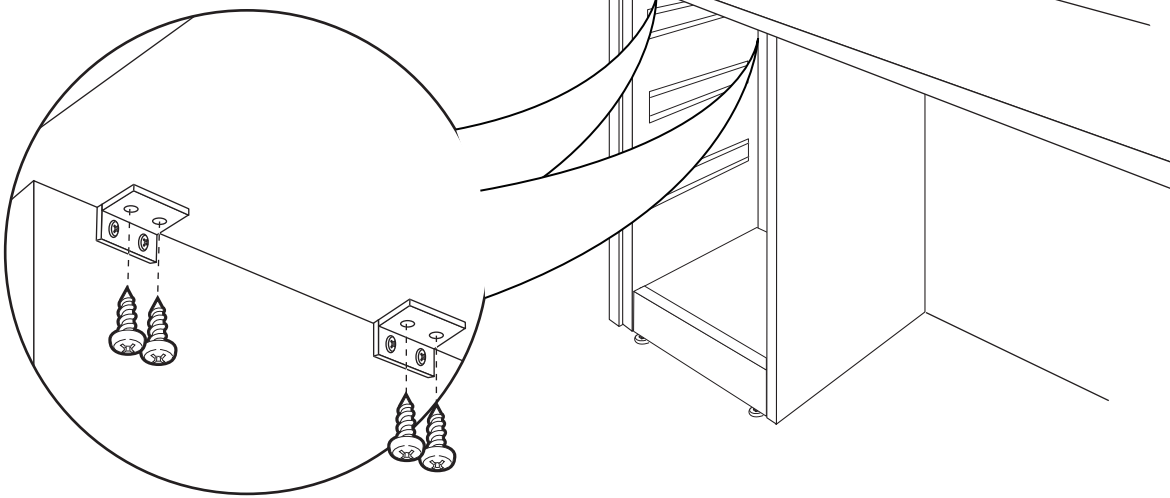

Step

6

Before installing drawers, move all box drawer Ball Bearing Inserts to extreme front position.

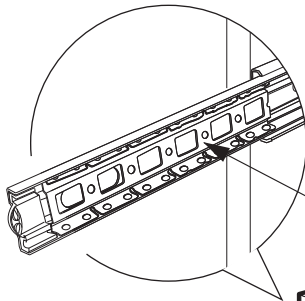

Ball Bearing Insert

