

NL3024RWL  
NL3624RWL  
NL4224RWL  
NL4824RWL  
NL5424RWL

# Assembly Instructions

Thank you for purchasing this product from Global. Before you begin assembly, check that you have all the parts and hardware shown on this page.

If there is any item missing, circle the item, indicating quantity required and return to us by fax or mail:

## CANADA

Global Upholstery  
560 Supertest Road  
Downsview, Ont.  
M3J 2M6  
TEL. (416)661-3660  
FAX. (416)661-4300  
Attn.: Customer Service

## US

Global Industries Inc.  
17 West Stow ROAD  
P.O. 524  
Marlton, NJ 08053  
TEL. (856)596-3390  
FAX. (856)596-5684  
Attn.: Customer Service

### TOOLS REQUIRED

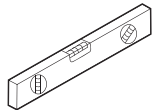

LEVELER

It is advisable to assemble unit on a carpet to avoid scratches.



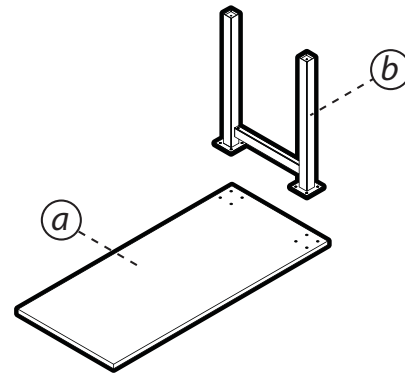

HANDDRILL



a. Top  
b. Metal Leg

**Notice to installers:**  
Open and assemble only one product at a time to avoid a potential mix up of parts and hardware.

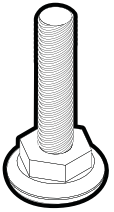
NAIN 15 rev: 00

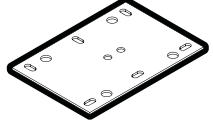
<p><b>FST158</b> SCREW 1/4"-20 X 3/4" P.H. QUAD ZINC</p>  <p>X8</p>	<p><b>GEN427</b> 5/16"-18 x 1 1/2" x 15/16" base</p>  <p>X2</p>	<p><b>FST028</b> #8 x 3/4 Pan HD.</p>  <p>X12</p>	<p><b>CST318</b> Transaction Top Flat Plate</p>  <p>X2</p>
<p>PACKED WITH METAL LEG</p>			

# Configurations

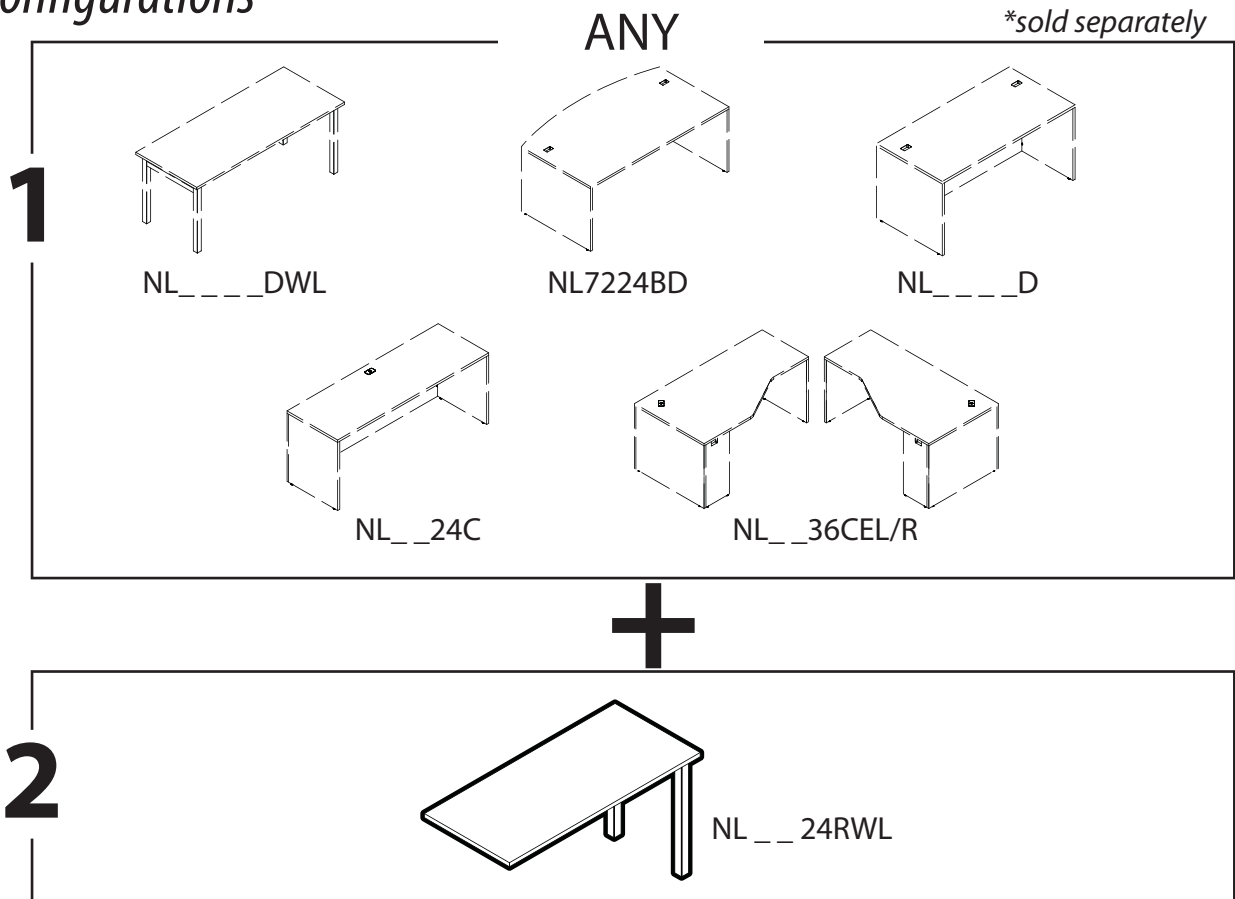

Step **1**

FST158  
X 8

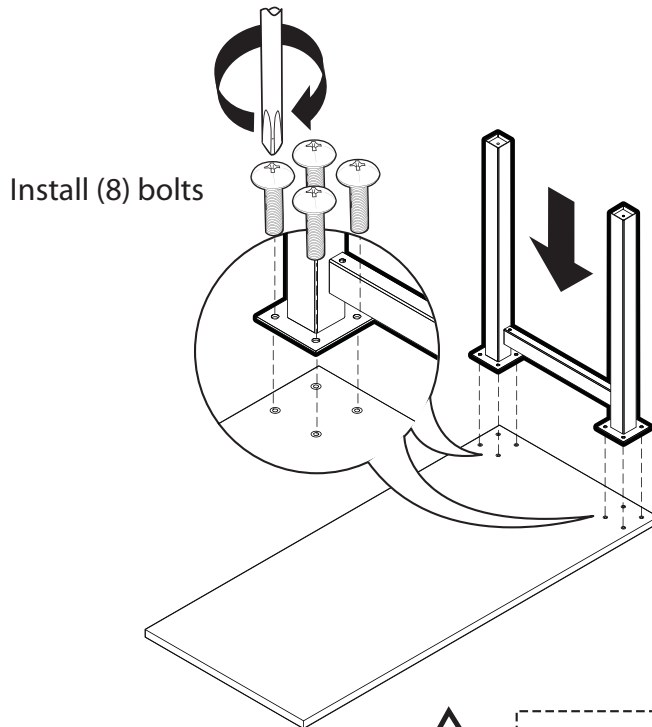

Locate and Level the Return in room before you proceed to the next step.

Step 2

GEN427

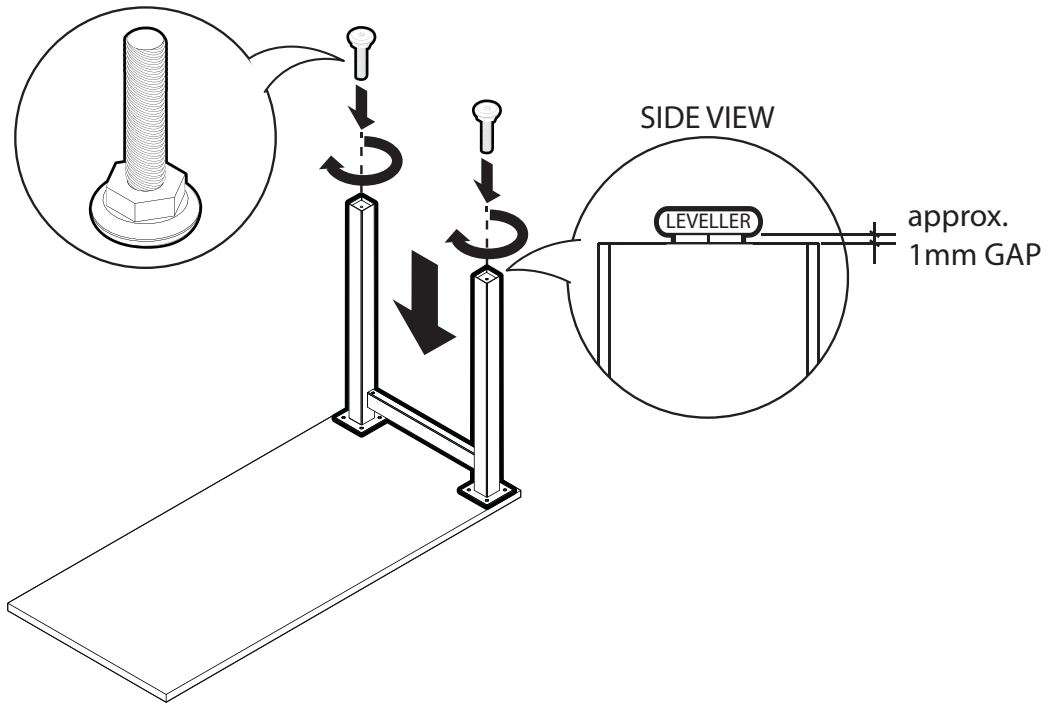
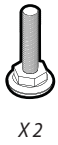

Step 3

FST028



CST318

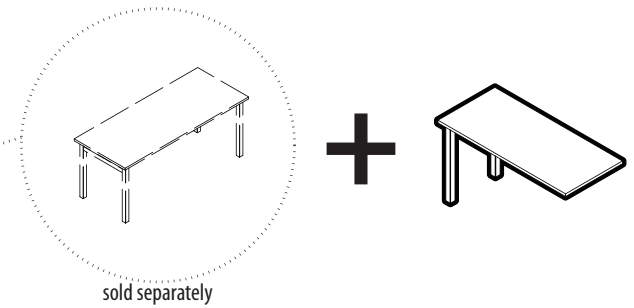
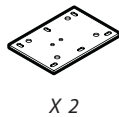

TOP VIEW

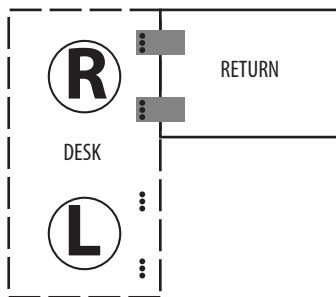

OR

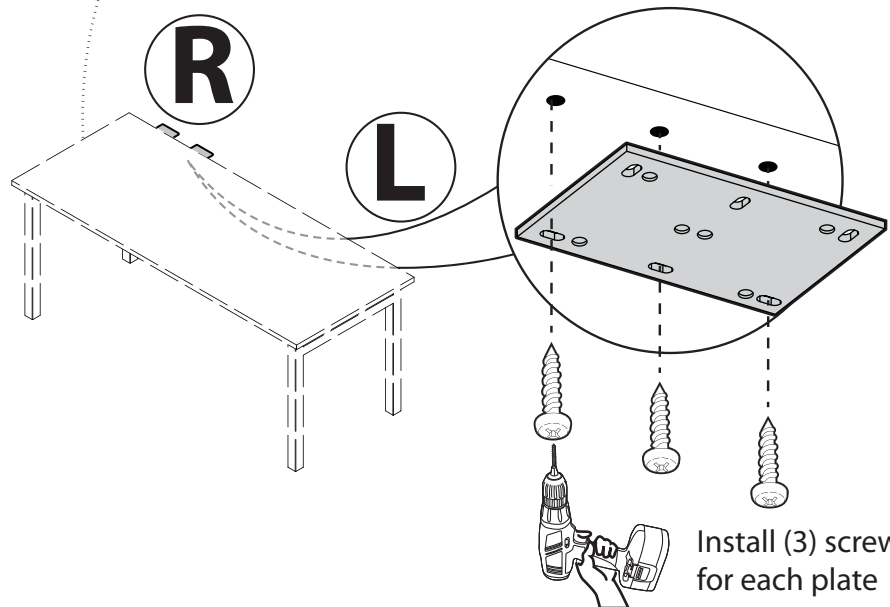
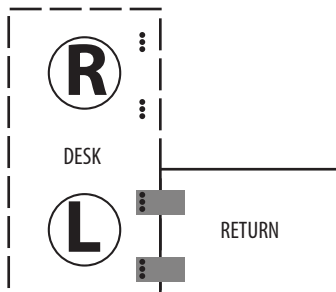

Step

4

FST028



X6

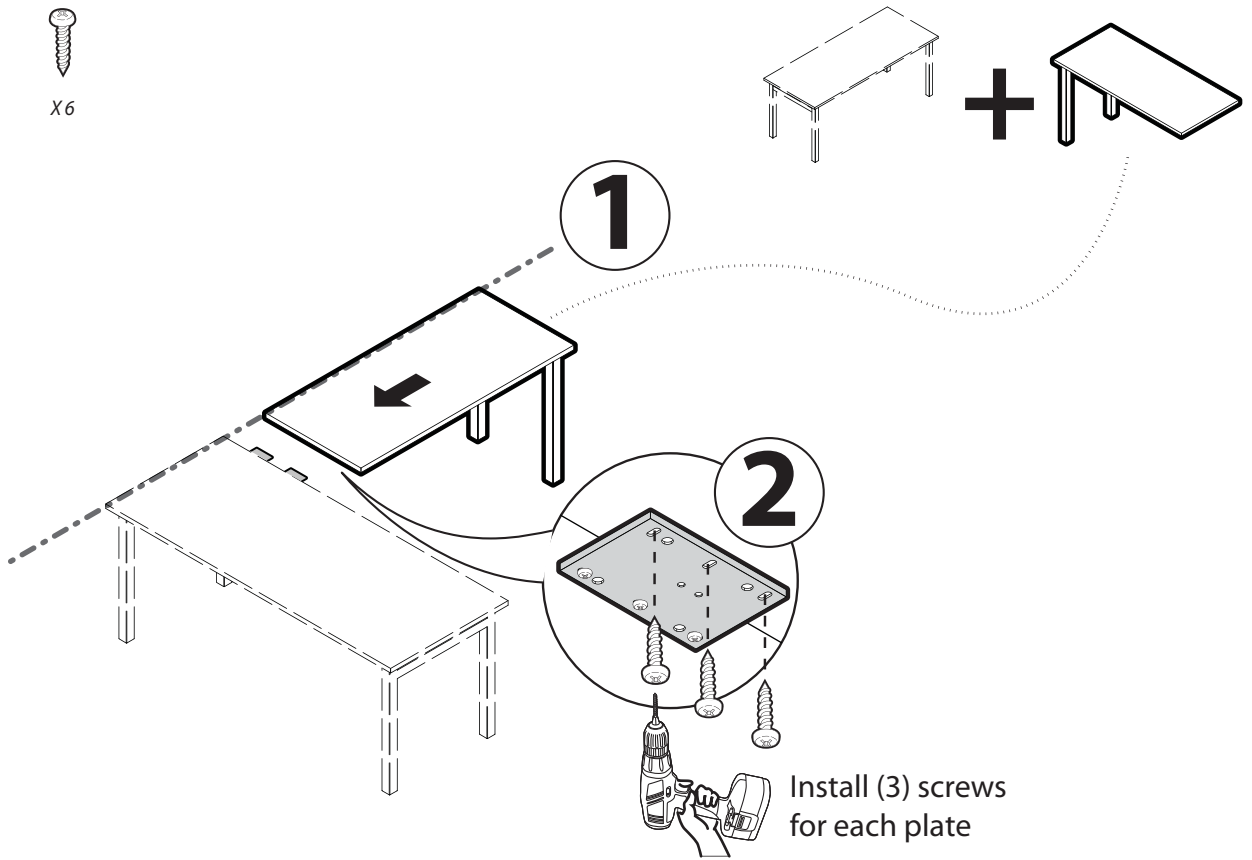

Step

5

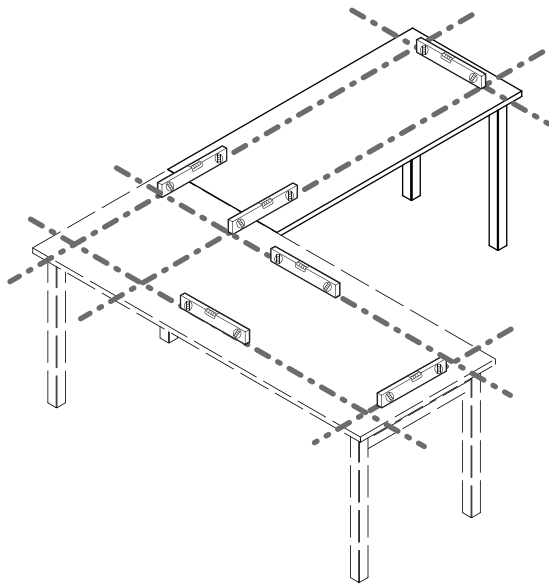

Leveler adjustment

