

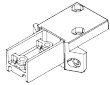





ASSEMBLY INSTRUCTIONS INSTRUCTIONS DE MONTAGE

| A | B | C | D | E | F | G |
|---|---|---|---|--|---|---|
|  |  |  |  |  |  |  |
| connector connecteur | leg pied | locker bloc d'arrêt | M8X20 | M8X16 | φ38 leveler φ38 patin | end cap embout |

1 detail

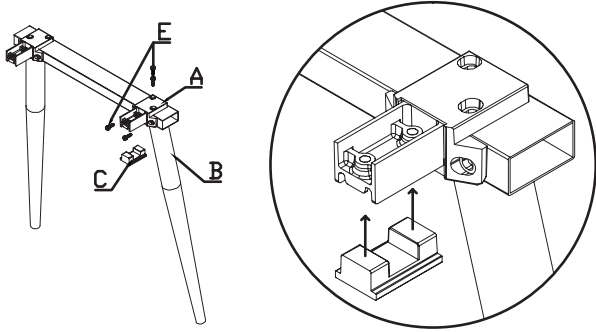

1. Install Connector (A) on Leg (B) with Screw (E)
Installer le connecteur (A) sur le pied (B) à l'aide des vis (E)
2. Insert Locker (C) on Connector (A)
Insérer le bloc d'arrêt (C) dans le connecteur (A)

2

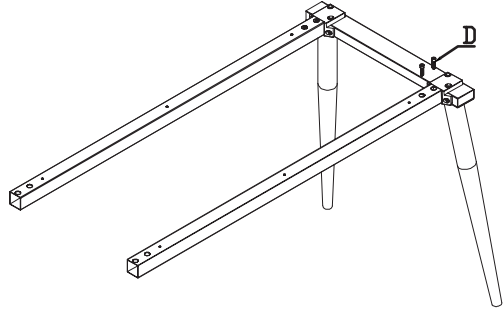

3. Install beam on Connector (A) with Screw (D)
Installer la traverse dans le connecteur (A) à l'aide des vis (D)
4. Repeat at each corner
Répéter à chaque coin

3

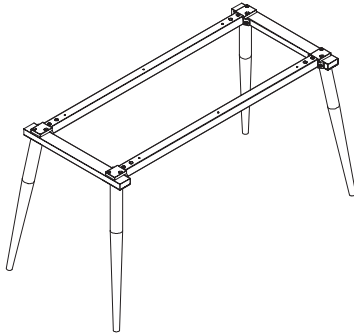

4

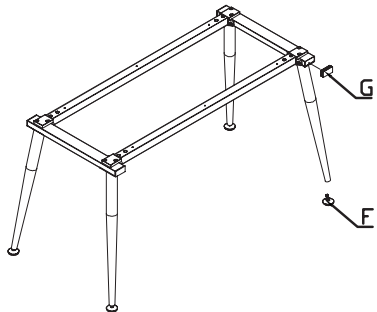

5. Install Leveler (F) and End cap (G)
Installer les patins (F) et les embouts (G)

5

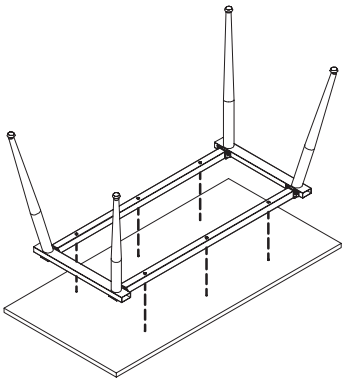

6. Align frame with pilot holes. Secure frame to top with wood screws provided with top surface
Aligner le châssis avec les avant-trous et assujettir le châssis au plateau à l'aide des vis à bois fournies avec le plateau